

# Collection Solution

## Chip Container SPB 50

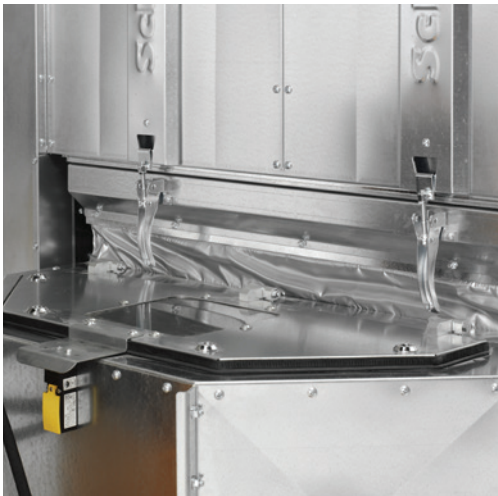

# Specific solutions for your mobile dust extractor

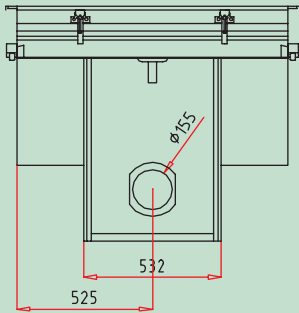

front view

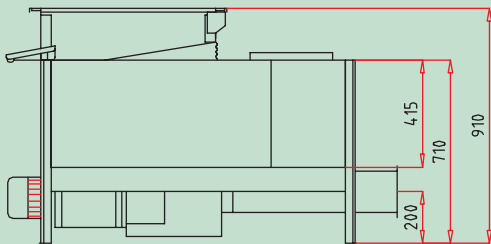

side view

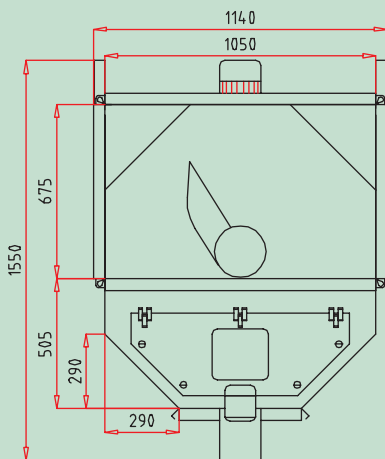

top view

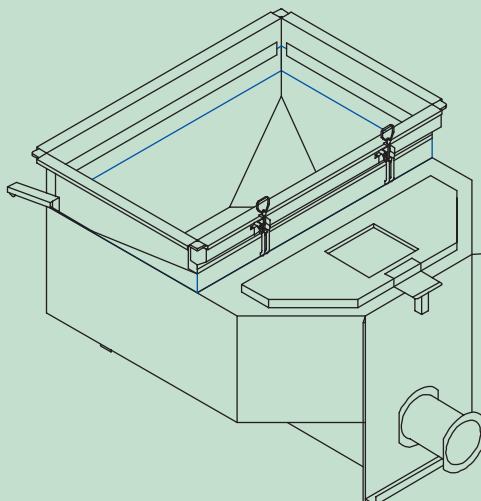

Dust extractor VACOMAT with chip collector SPB 50 and briquetting press Compacto 700

The Schuko chip collector type SPB 50 is designed for use in the substructure of our mobile dust extractors 180 XP and 180 XPe. It is attached onto the VACOMAT with a lead frame and an inspection/view flap. The motor has a power of 1,5 kW, 34,4 turns/min. The chip container is ready to plug in (includes power cable and plug) and a phase inverter is provided.

Item number:	750120
Volume:	0,47 m <sup>3</sup>
Motor drive:	1.5 kW 34.4 U/min
Weight:	200 kg
Dimensions (L x W x H):	1,550 x 1,140 x 910 mm

Dealer address



[www.schuko.com](http://www.schuko.com)

Schuko International GmbH & Co. KG

Gewerbegebiet Zossener Str. 4  
14959 Trebbin, Germany

☎ +49 (0) 3 37 31 / 77 77 - 94 ou 95  
Téléfax +49 (0) 3 37 31 / 77 77 - 96

Email: [international@schuko.com](mailto:international@schuko.com)